

Energy Utilization in Brick Kilns

Sameer Maithel

PhD Seminar, December 2003

Energy Systems Engineering, IIT Bombay

Supervisor: Prof. A W Date

Outline

- Introduction
- Bull's Trench Brick Kiln
 - Experimental Investigations
 - mass and energy balance, brick and gas temperature distribution
 - Analysis of ground heat loss
- Vertical Shaft Brick Kiln
 - Experimental Investigations
 - mass and energy balance, brick temperature distribution
 - 1-D combustion and heat transfer simulation
- Conclusions

The Context

- Important energy consuming industrial end use in India.

≈ 140 billion bricks/yr.

≈ Coal: 24 million tons/yr

≈ Biomass: >5 million tons/yr

- Environmental concerns:
Local and Global

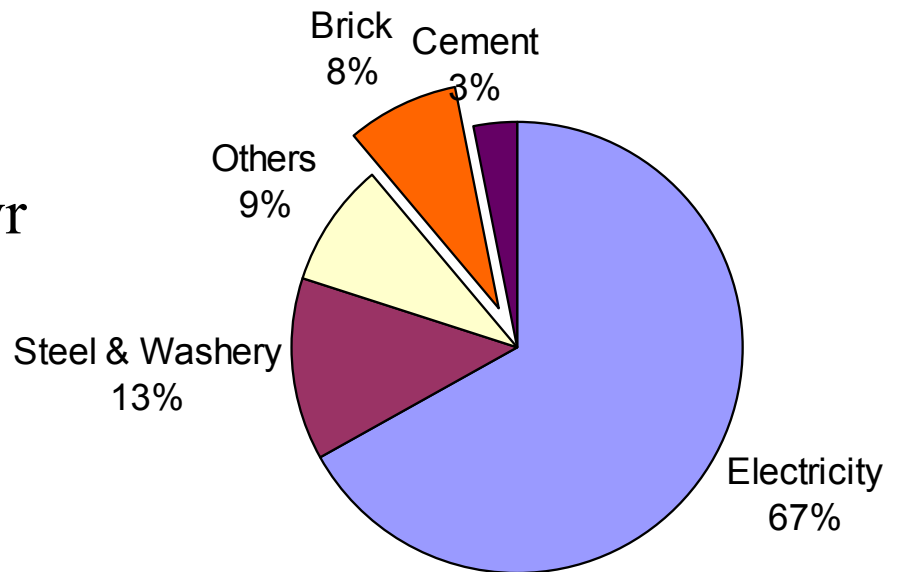

Coal Consuming Sectors

Brick Kilns

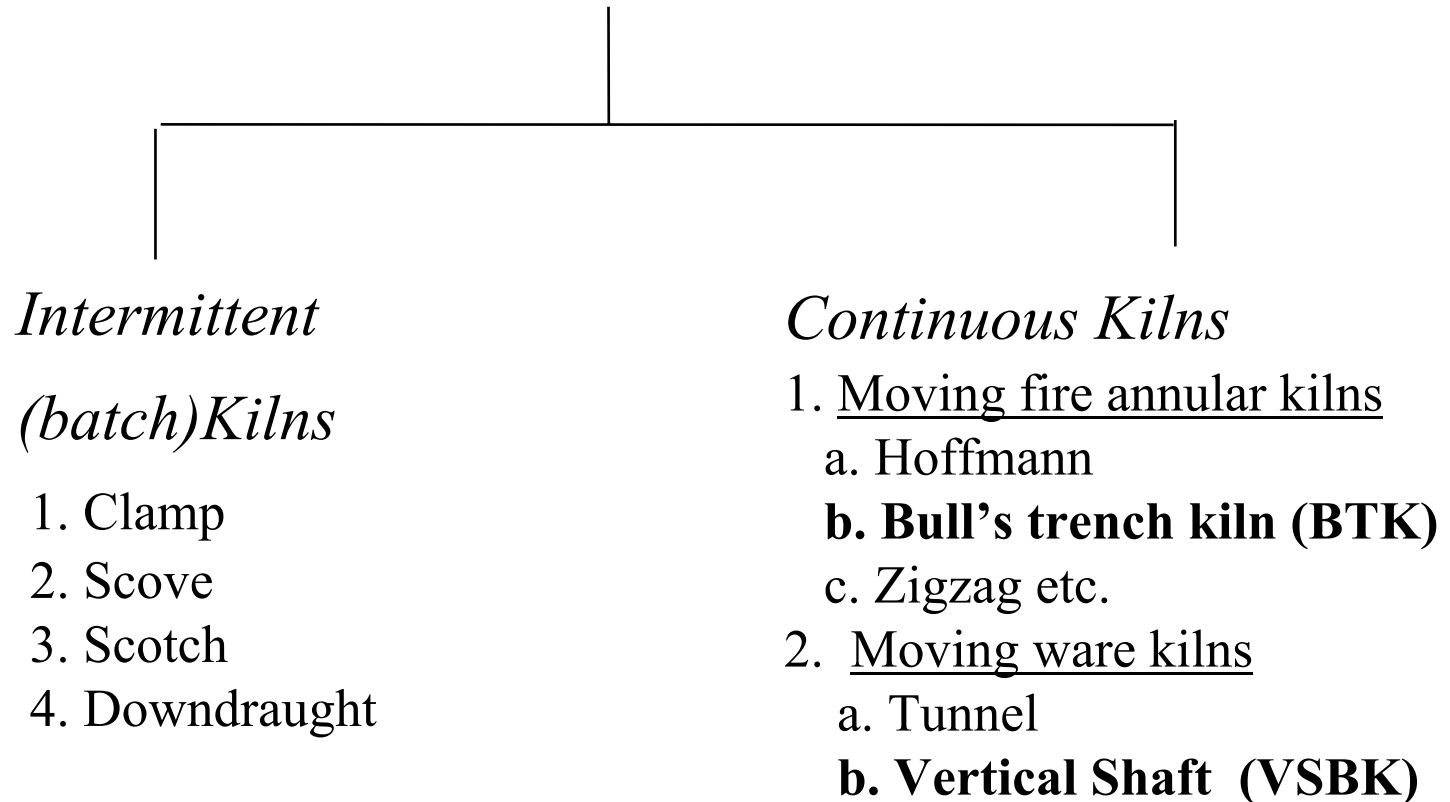

Important Physical and Chemical Changes during Brick Firing

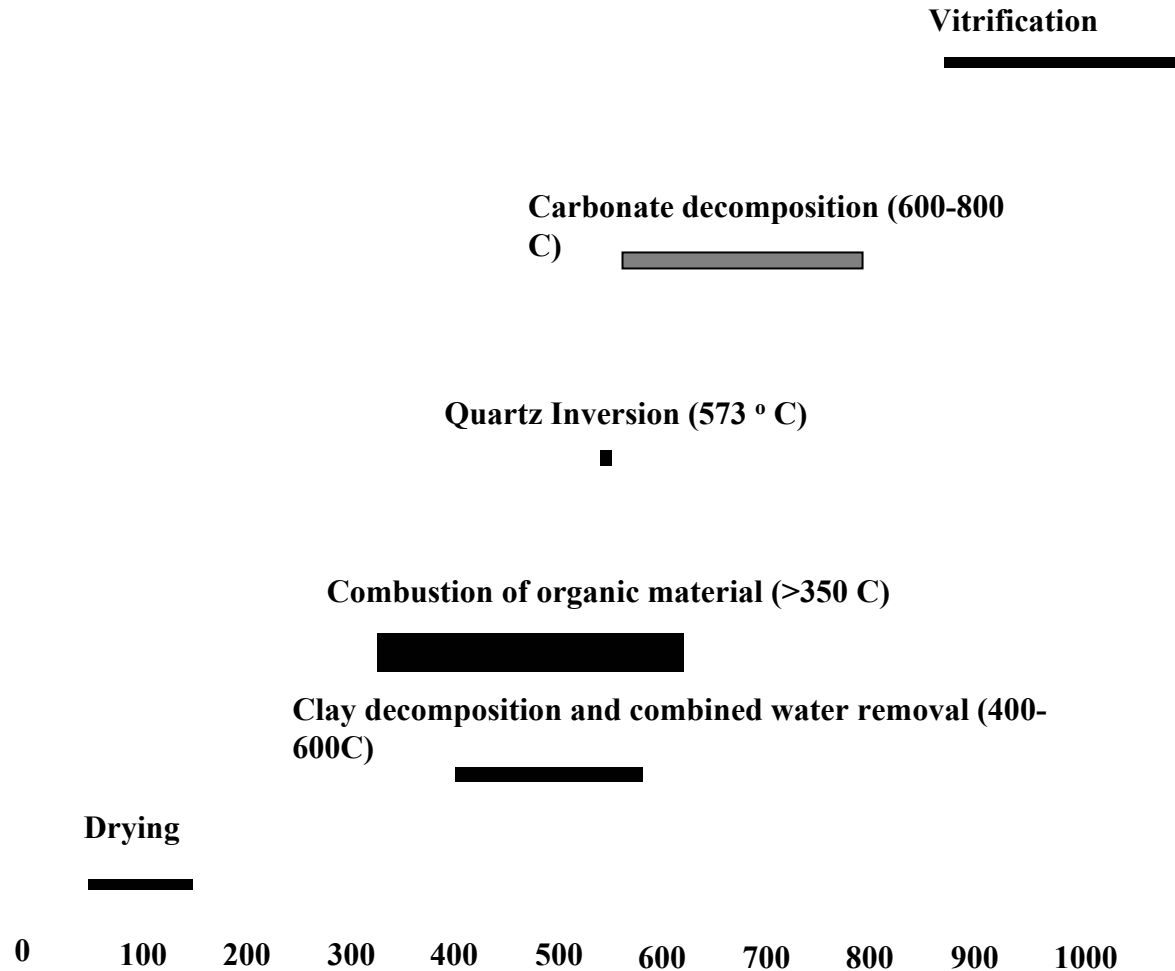

Brick firing involves heating, soaking and cooling

Brick Kiln: Material Balance

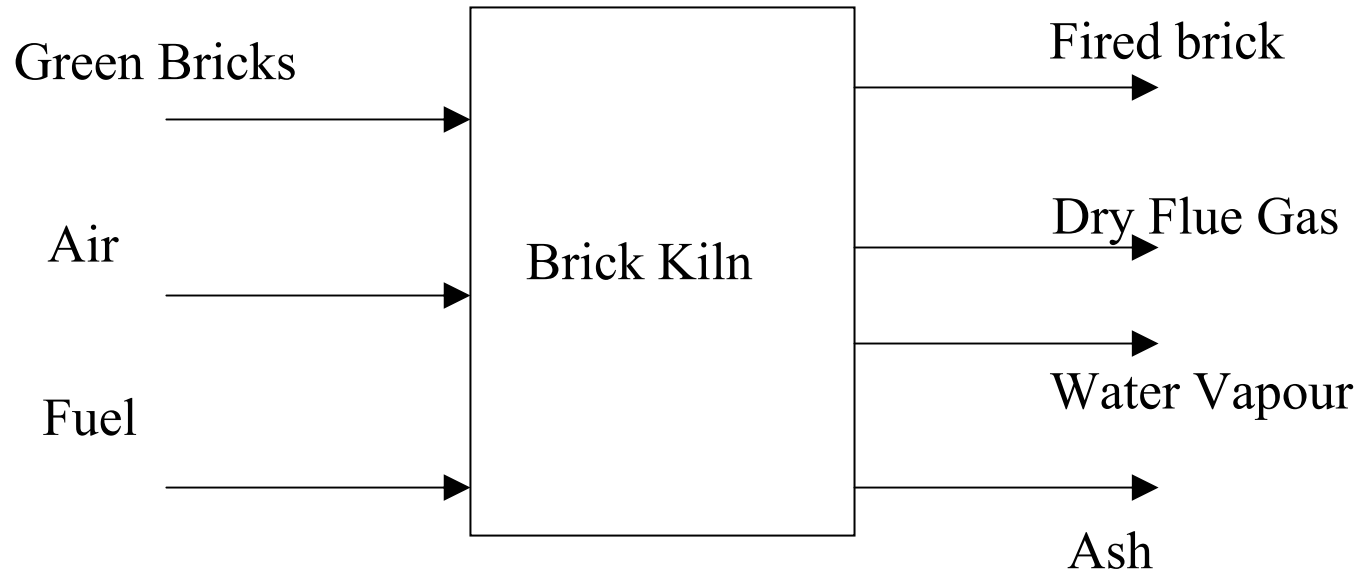

Energy Balance

Heat input (Q_{in})

1. Fuel added in the kiln (Q_{fe})
2. Combustible material present inside the brick (Q_{fi})

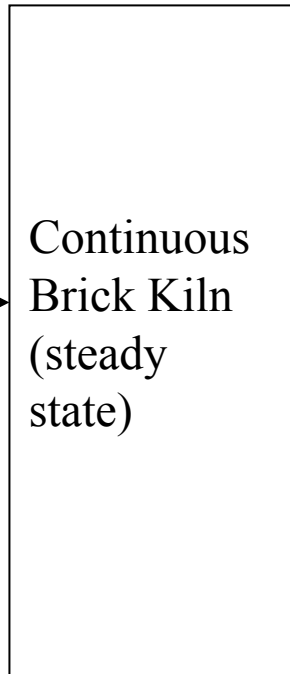

1. Convective and radiative heat loss from the outside surface of the overground kiln structure (Q_{sur})
2. Heat conduction to the underground kiln structure (Q_{gr})
3. Irreversible chemical reactions in the brick (Q_r)
4. Sensible heat
 - fired bricks (Q_{fbr})
 - dry flue gases leaving the system (Q_{fg})
5. Chemical energy
 - CO and other incomplete combustion products leaving the system with flue gas (Q_{co})
 - Potential heat in the unburned char in the ash (Q_{ash})
6. Enthalpy in water vapour leaving the system (Q_v)
 - From residual mechanical water in green bricks ($Q_{v, mech}$)
 - From combined water generated during the dissociation of clay minerals ($Q_{v, chw}$)
 - From combustion of hydrogen contained in the fuel ($Q_{v, H2}$)
 - Moisture in coal ($Q_{v, coal}$)

Bull's Trench Kiln (BTK)

Rationale for studying BTK

- Main kiln: 30,000 kilns; 75% brick production
- Literature survey:
 - Two experimental studies: Majumdar et al [1968] & TERI [1995]
 - No analytical study
- Gaps in knowledge
 - Incomplete energy balance statements
 - Q_{gr} not studied
 - Large unaccounted energy losses.
 - Large uncertainties in energy balance components
 - Q_{fg} (60.8%) in Majumdar; Q_{fg} (7.6%) in TERI.
 - Brick and gas temperature distribution not available.
 - Air leakage in the system not studied

BTK – Working Principle

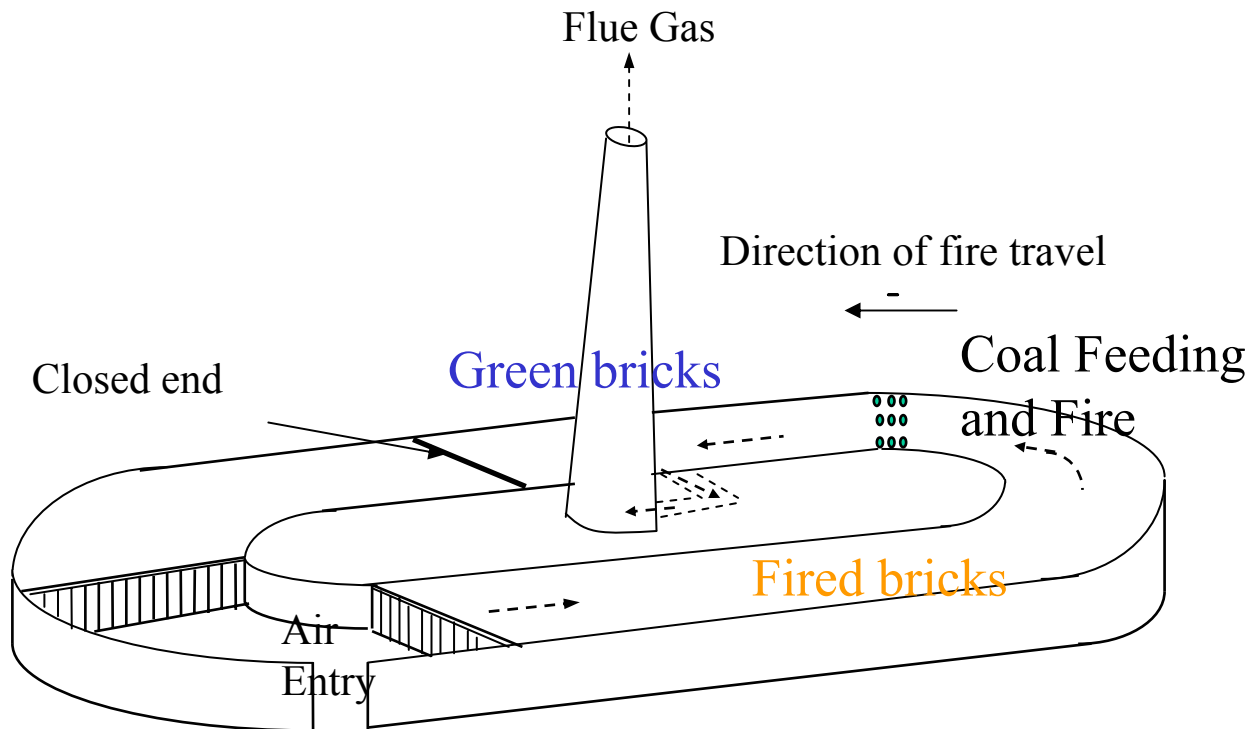

Brick Setting



Coal Feeding



- From feed holes on kiln roof
- Manual and Intermittent
- Coal burns on ledges and on ground

Coal Feed

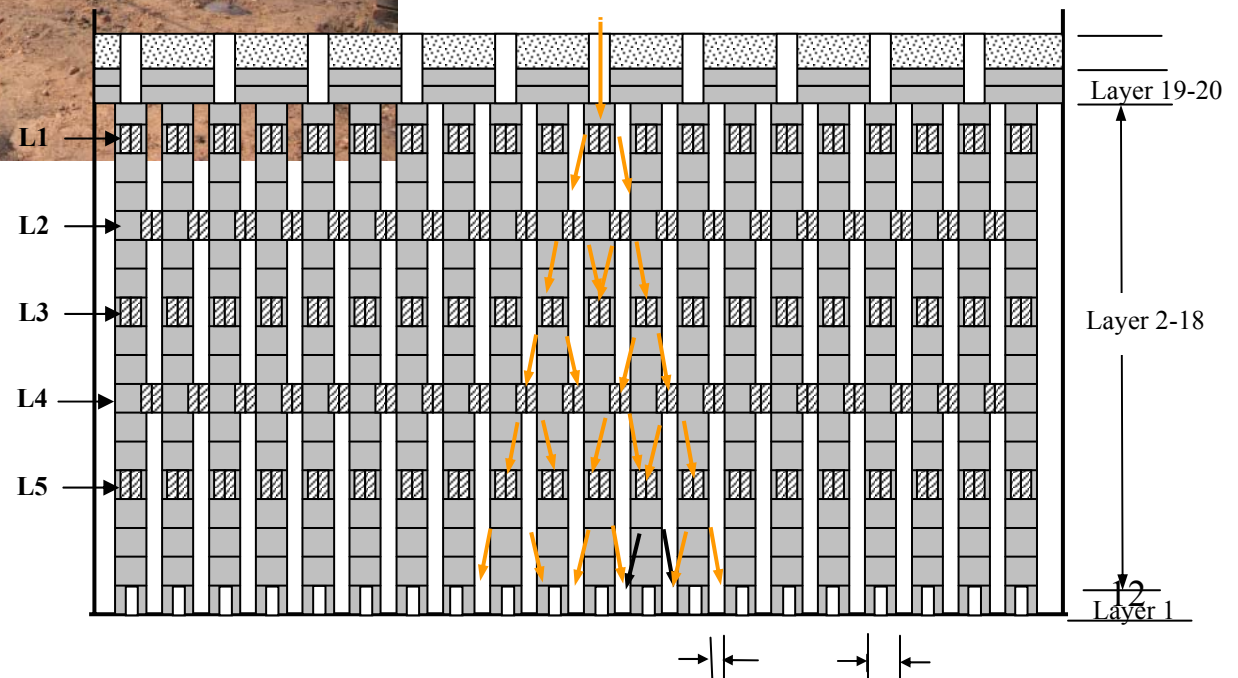

BTK, Kulpi

- Location

70 km south of Kolkatta along Hooghly river.

- Preparatory visits: March 1998 & Dec. 1998

- Experiments:

- March 10 – April 5, 1999
- Periodic steady-state condition
- Measurement covering one full firing cycle



Temperature Measurement

Start (March 18, 1999)

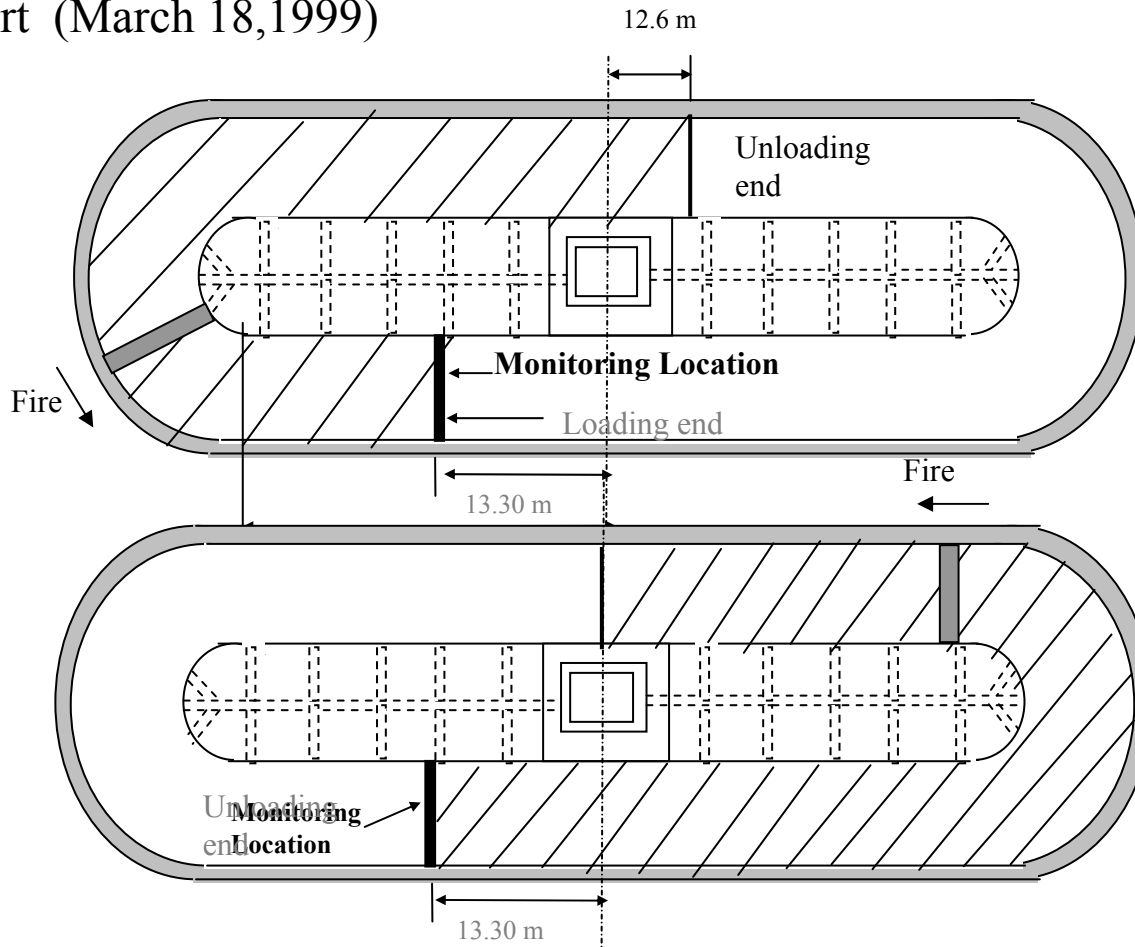

- Fixed Location
- Covering one full firing cycle (15 days)
 - Brick
 - Gas
 - Ground
 - Kiln surface (roof, side walls)

Completion (April 1, 1999)



Active Part

Brick & Gas: Thermocouple location

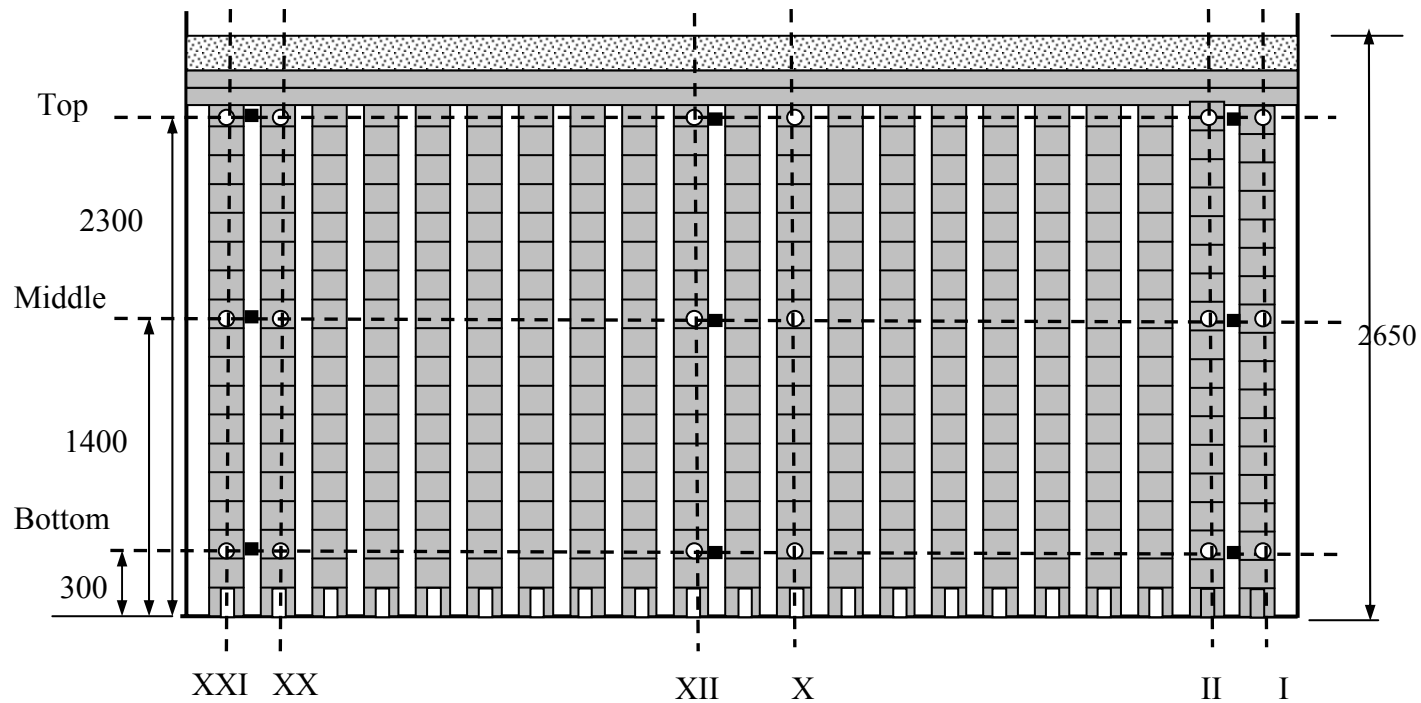

○ Brick t/c locations (18 nos.)

■ Gas t/c locations (9 nos)

Brick Thermocouple Assembly

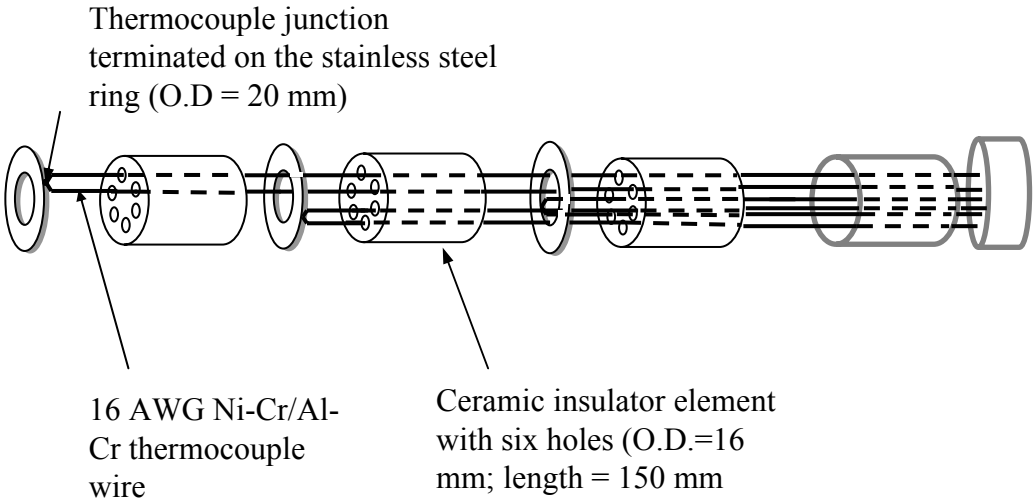
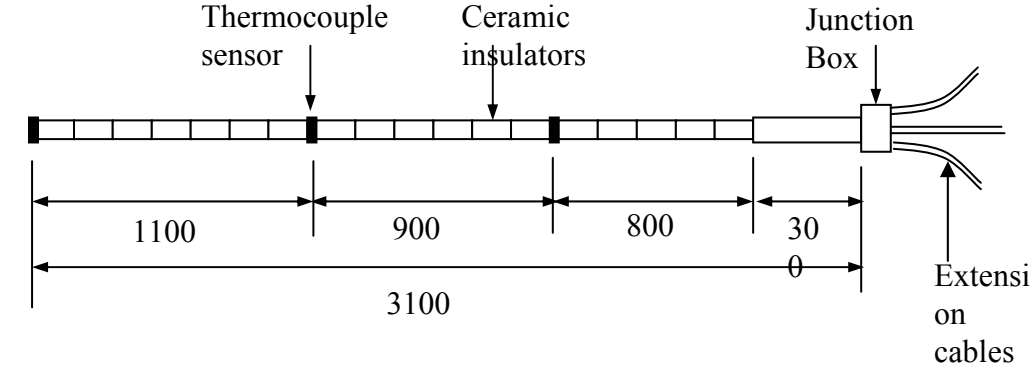

Temperature Measurement

- Care taken not to introduce any intermediate metal : Extension cables and connectors of chromel/alumel.
- Extension cable insulation: polyester film, fiberglass braid with varnish impregnation (protection from moisture).
- After connecting thermocouple assemblies with extension cable, checked for reverse polarity at the thermocouple – extension wire junction.
- Temperature scanner: Resolution = 1°C ; Accuracy = $\pm 2^{\circ}\text{C}$; cold junction compensation using electronic circuit.
- (Frequency of temp. measurement = 900 s) > (Time constant for SS ring = 359 s for $h=10\text{W}/\text{m}^2\text{K}$)
- Temperatures manually recorded; frequency of measurement 15/ 30/60 min.

Temperature Measurement

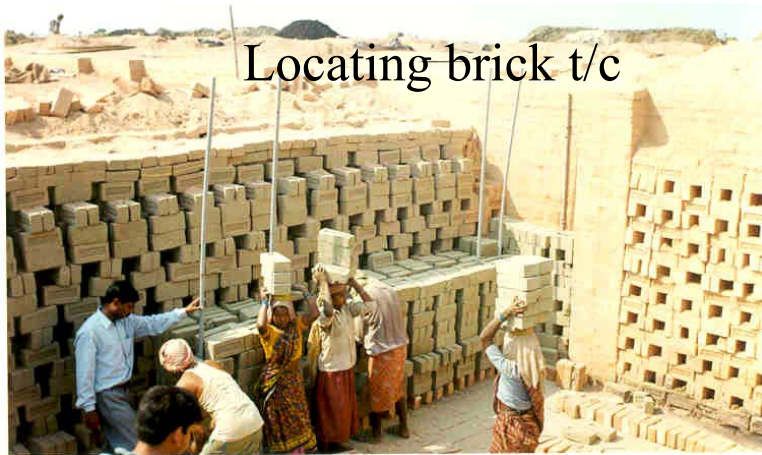

Locating brick t/c



Control room being constructed

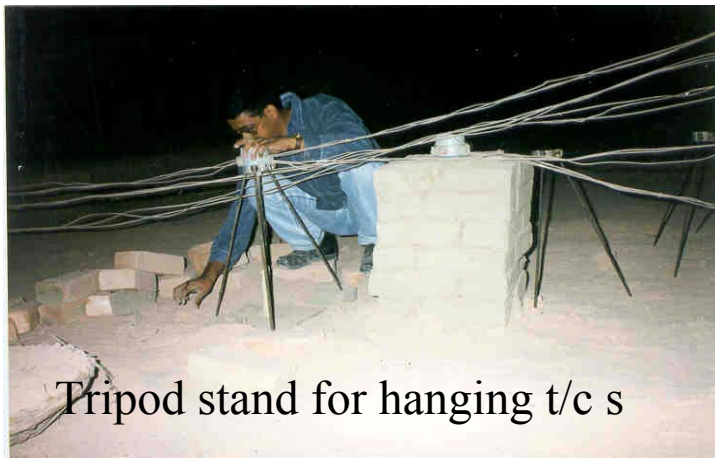

Tripod stand for hanging t/c s

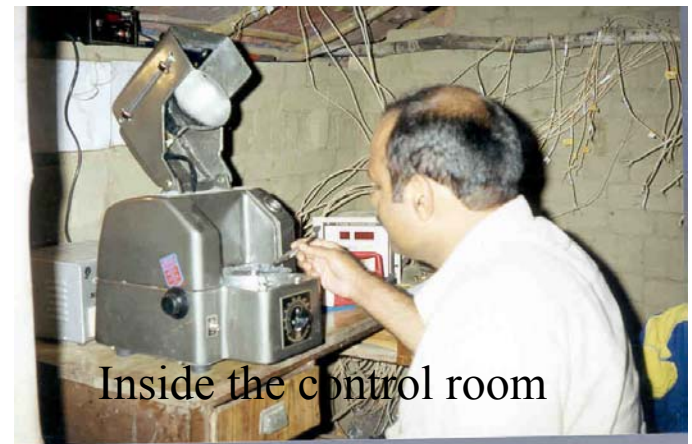

Inside the control room

Brick Temperatures

- Stratification in vertical direction
- Top temperatures
 - Lower in the firing zone
 - Higher in heating and cooling zone
- Primary Causes
 - Non uniformity in gas flow
 - Non uniformity in coal distribution

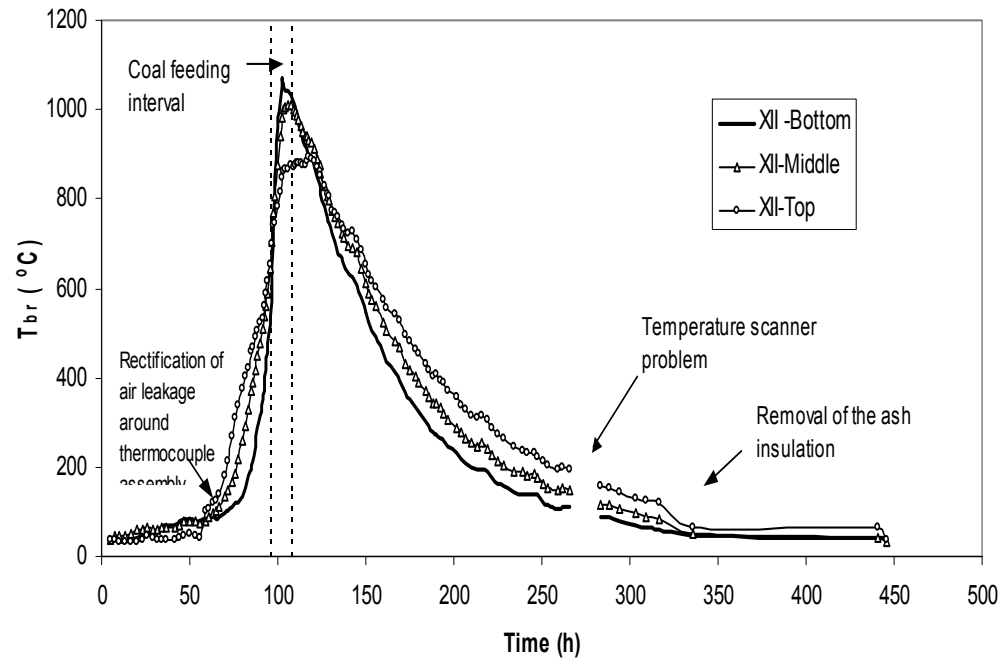

Gas Flow: Physical Explanation

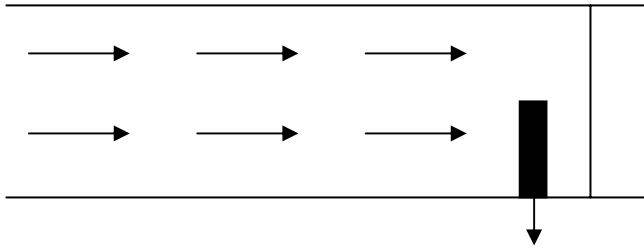

I. Only Draught; No Fire

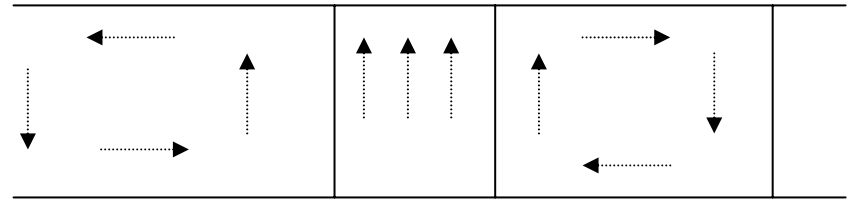

II. Only Fire; No Draught

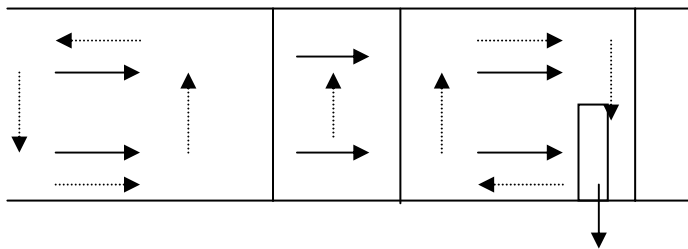

Real Kiln (Resultant of I & II)

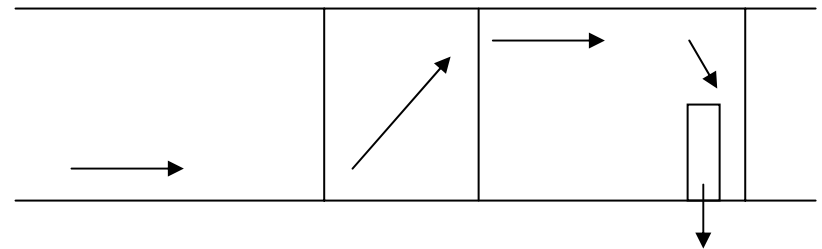

Temperature Distribution along the Length of the Kiln

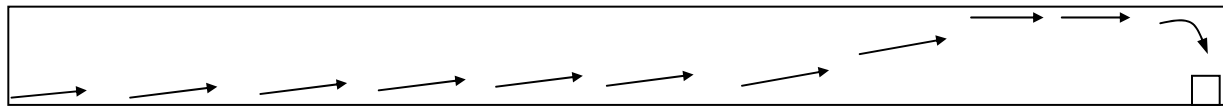
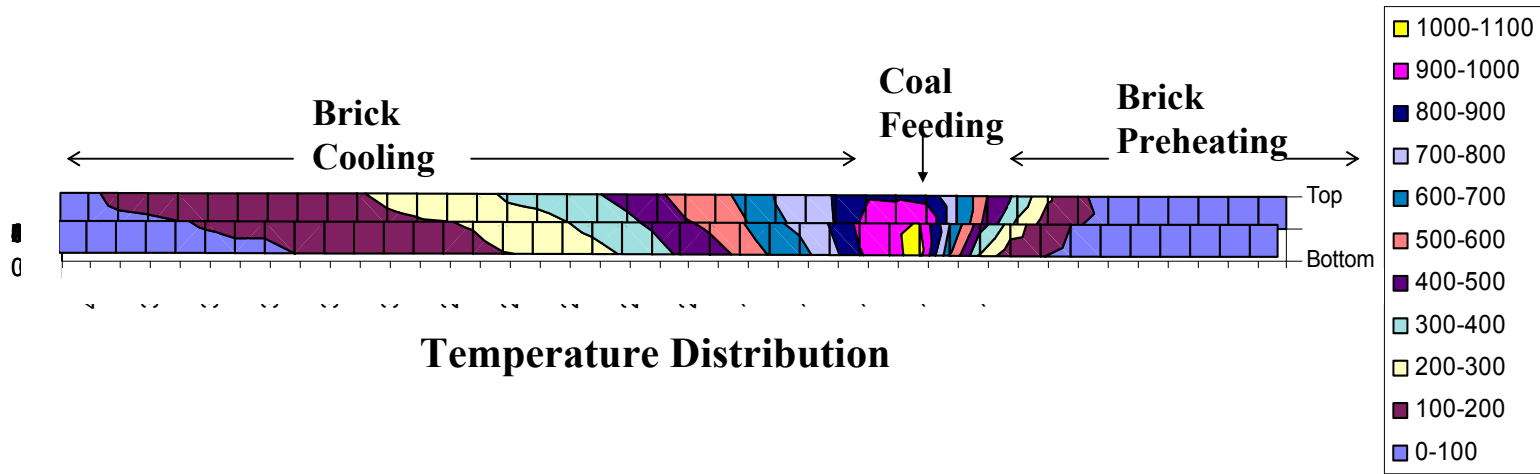

Gas flow in the kiln

Brick temperature distribution and its effect on brick quality

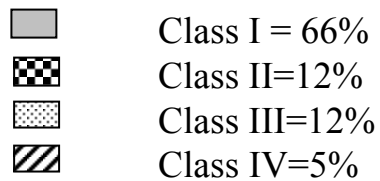
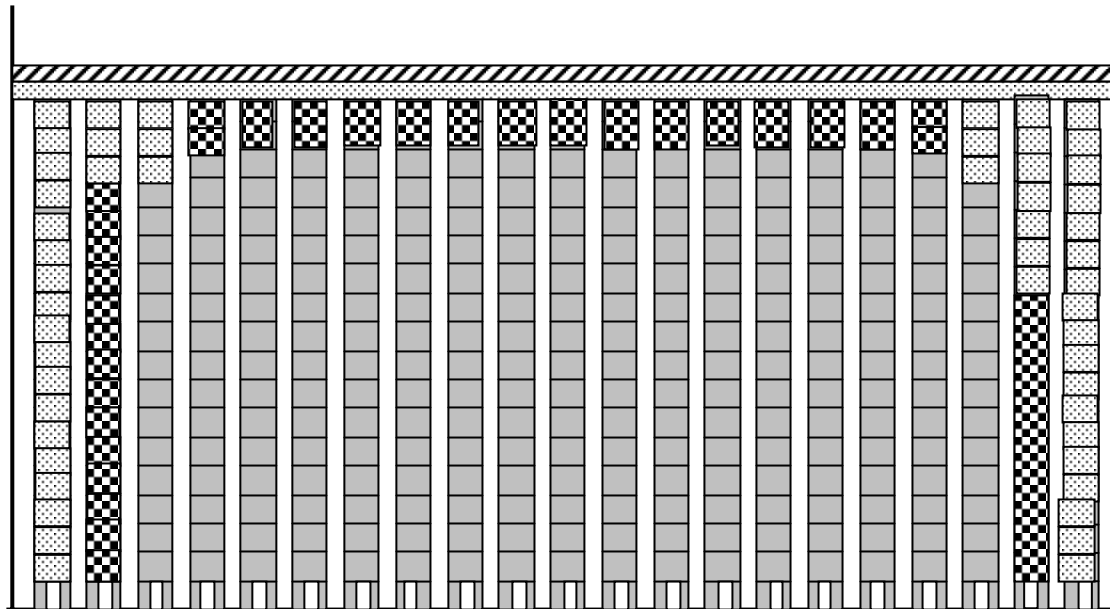

Ground Thermocouples

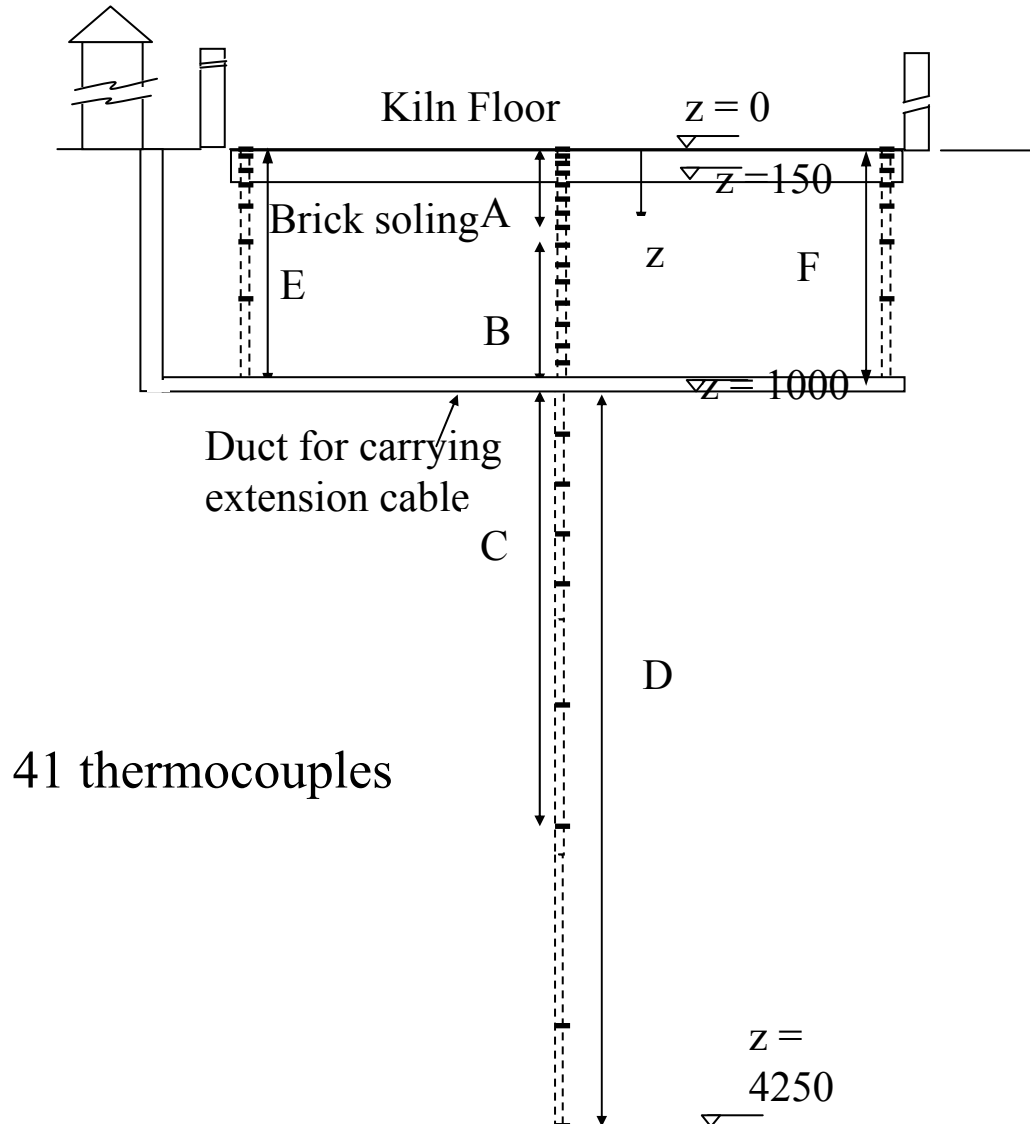

Installation of Ground Thermocouples



Trench for installing
ground t/c



Installed thermocouples

Ground Temperatures

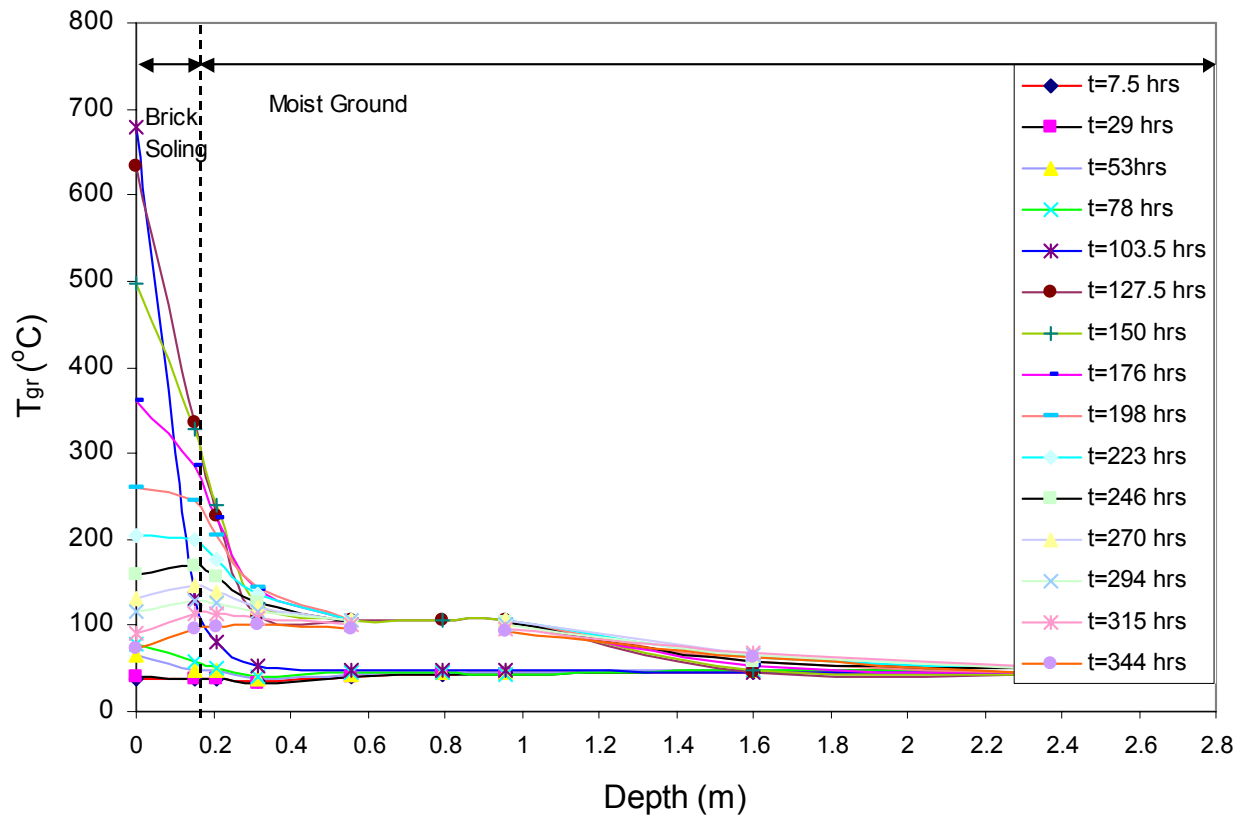

Flue Gas Monitoring

- O_2 , CO_2 , CO , T_{fg}
- Entry to chamber flue (location IV)
- Varying with time (coal feed operation)
- Air ingress (additional measurements I, II, III, V).
- Frequency : 12 hrs
- Each measurement: 3 readings during coal feeding and 3 during non feeding (evenly spaced)

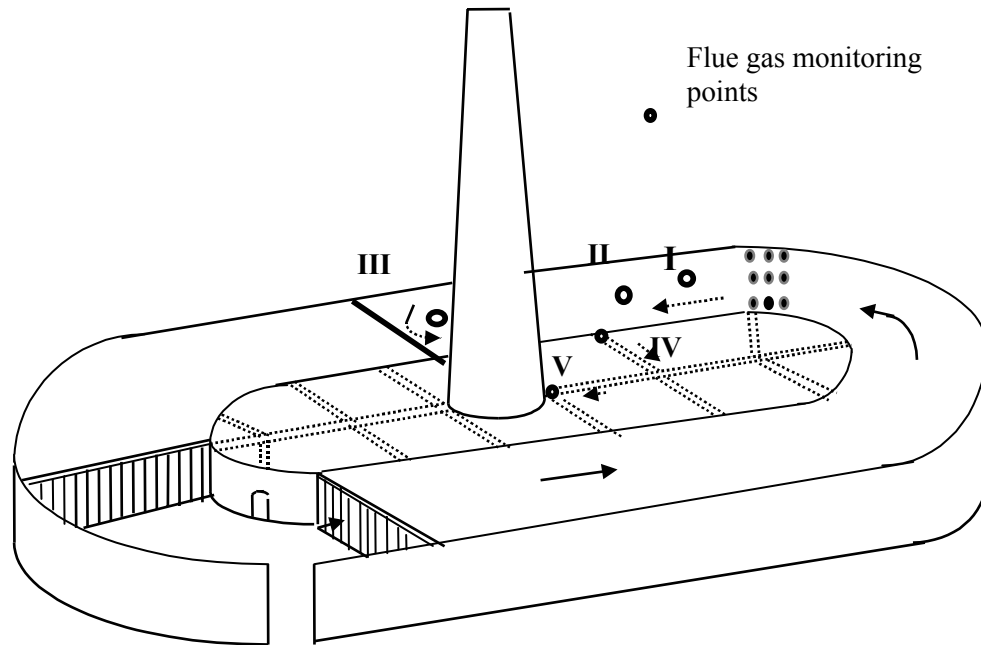

Flue Gas Analyzer

- O_2
 - Range (1-25%)
 - Electrochemical sensor
- CO_2
 - Range (0-20%)
 - Derived
- CO
 - 0-10000 ppm
 - Electrochemical sensor
- T_{fg}
 - 0-1000 °C
 - Type K



Probe, filter, condensate trap, display unit

Flue Gas – Typical variation over a coal feeding cycle

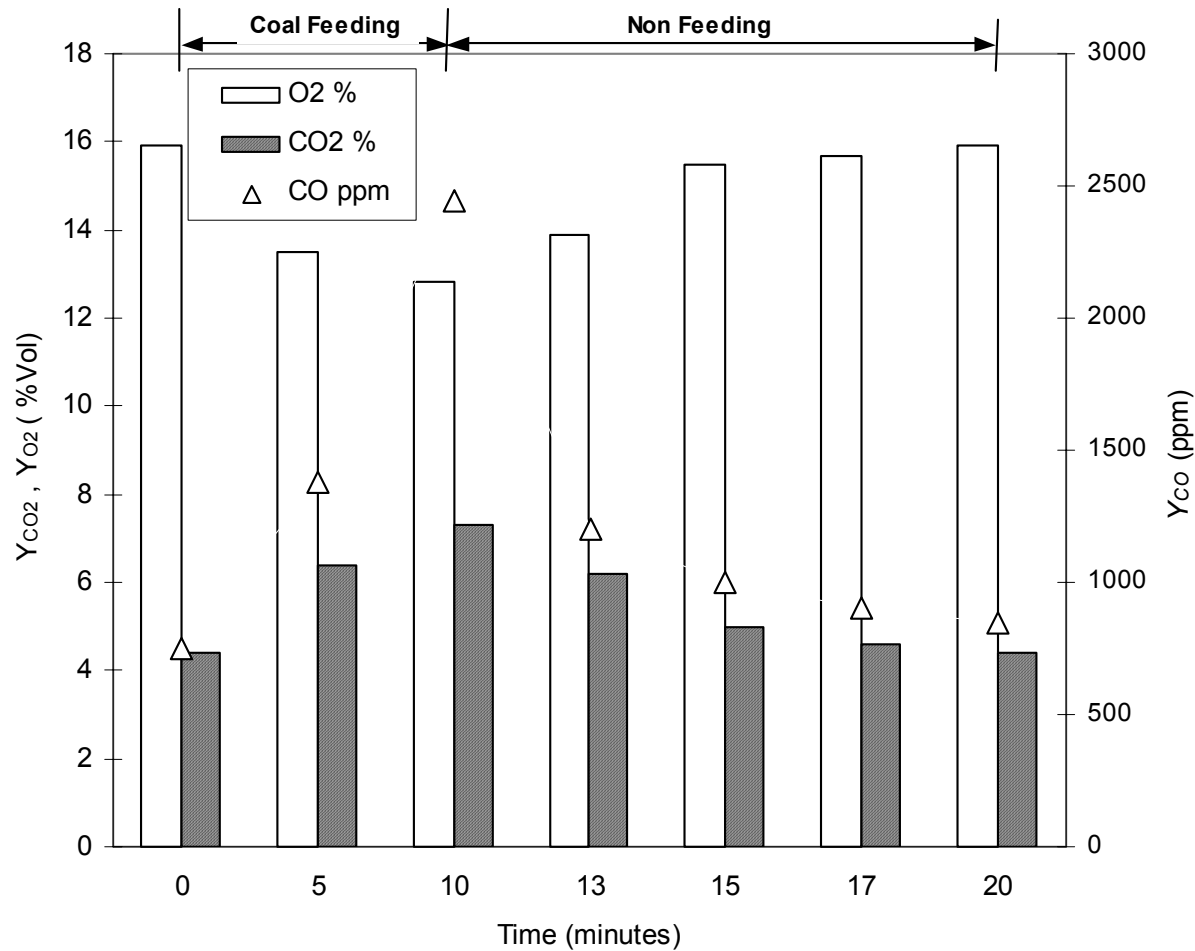

Flue Gas Results

- 60 data points over 15 days
- Weighted average during coal feeding and non-feeding.
 - O₂ : 14.06 % (10.1 – 17.1)
 - CO₂: 6.33 % (3.4 – 9.6)
 - CO: 1458 ppm (630-3870)
- Excess Air: 179%

Calculations based on stoichiometric air requirement

BTK: Mass Balance

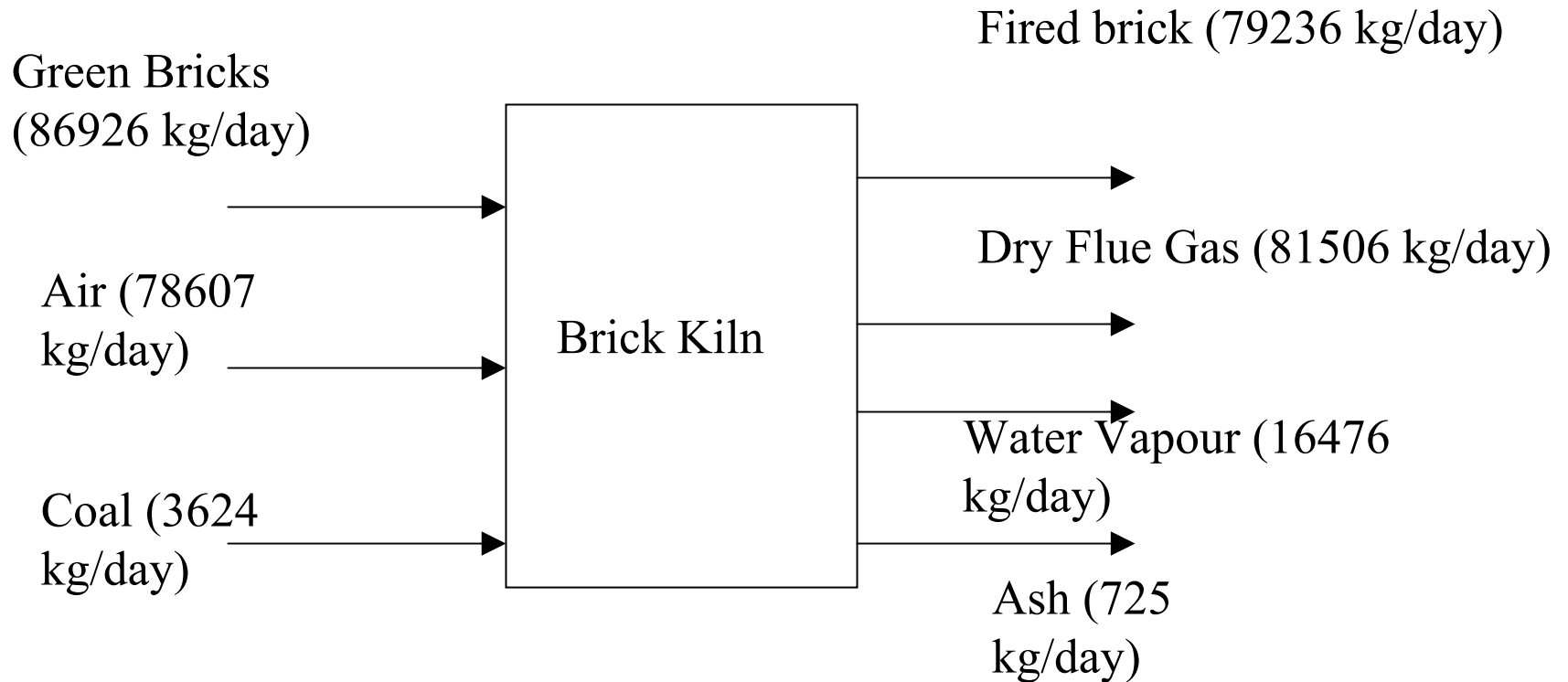

BTK: Energy Balance

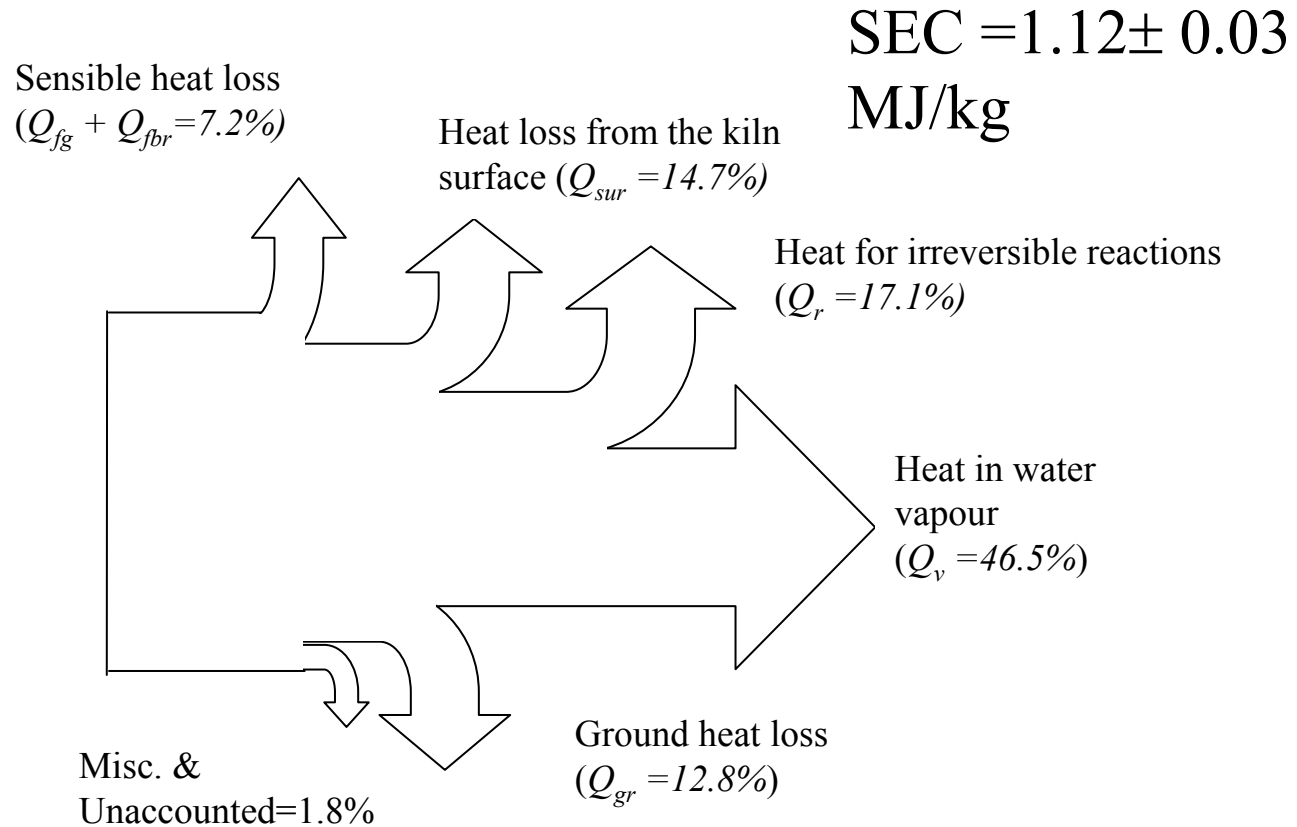

Uncertainty Analysis

- Uncertainties due to least count, instrument accuracy are relatively small (e.g 2.7% in SEC).
- Repeatability : Not possible in plant data (several external factors – e.g. ambient, production related which are beyond the control of the experimenter; cost factors)
- Large no. of measurements taken over one full firing cycle (15 days) to capture variations in kiln performance and reduce the effect of external factors/happenings on the average values.
- Uncertainty in two calculated energy balance components (Q_{gr} and Q_{sur}) can be significant depending on the assumptions made.

Uncertainty Analysis

- Q_{gr}
 - ‘k’ for brick floor not determined experimentally.
 - ‘k’ for fired bricks 0.41-0.81 W/m-K [literature]
 - intermediate value $k(T) = 0.41 + T \times 3.5 \times 10^{-4}$ W/m-K was selected keeping in view low density of bricks.
 - Higher value of $k = 0.81$ W/m-K would increase Q_{gr} by 44%.
- Q_{sur}
 - Kiln open to atmosphere; conditions alternate between still air to windy; difficult to choose a correlation for ‘h’; conservative approach (so that not to overestimate) adopted and natural convection correlation used.
 - $\pm 25\%$ uncertainty in h and $\pm 10\%$ in ε results in $\pm 12.5\%$ in Q_{gr} .
 - Average ambient temperature (T_{∞}) used in radiation heat loss from kiln roof. $T_{sky} = (T_{\infty} - 6)$ would result in 9% increase in Q_{roof} .

Analysis of Ground Heat Loss

- Simple analysis to get a feel for the factors influencing Q_{gr}
- Ground as semi-infinite medium

$$\frac{\partial}{\partial z} \left(k \frac{\partial T}{\partial z} \right) = \rho C_p \frac{\partial T}{\partial t}$$

- 1-D transient heat conduction

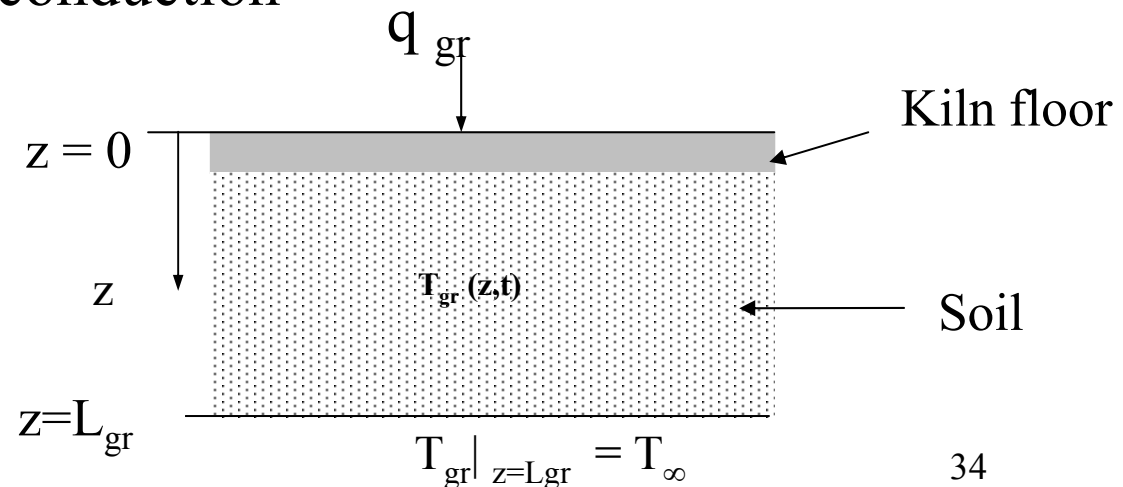

Analysis of Ground Heat Loss

- Finite difference method employed for solution.
- Δt and Δz chosen so as to satisfy the stability conditions.

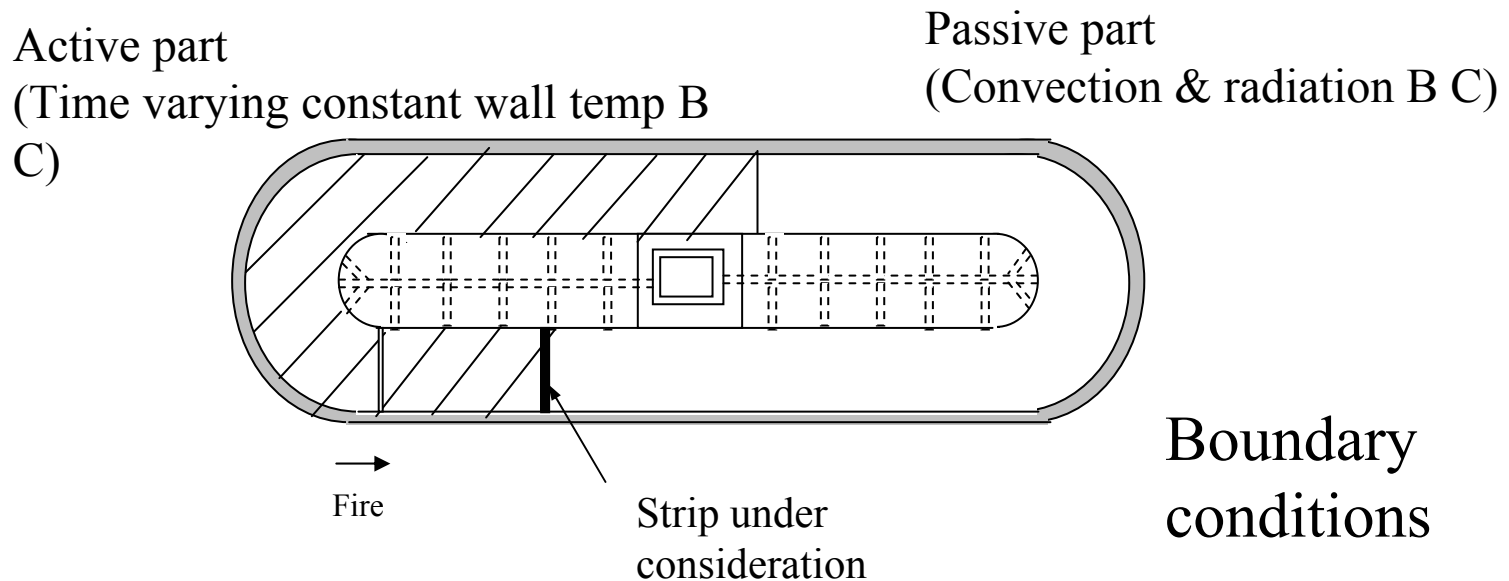

Analysis of Ground Heat Loss

- Fair degree of match between the predicted and measured ground temperatures for Kulpi kiln. Better match possible if moisture transport is also considered.
- Model (under dry soil condition) used to study the effect of:
 - Ground conditions (different soil densities)
 - Kiln floor (common brick, extruded, insulation, unpaved)
 - Kiln length (167 m, 125 m, 107 m)

Effect of ground thermal properties on Q_{gr}

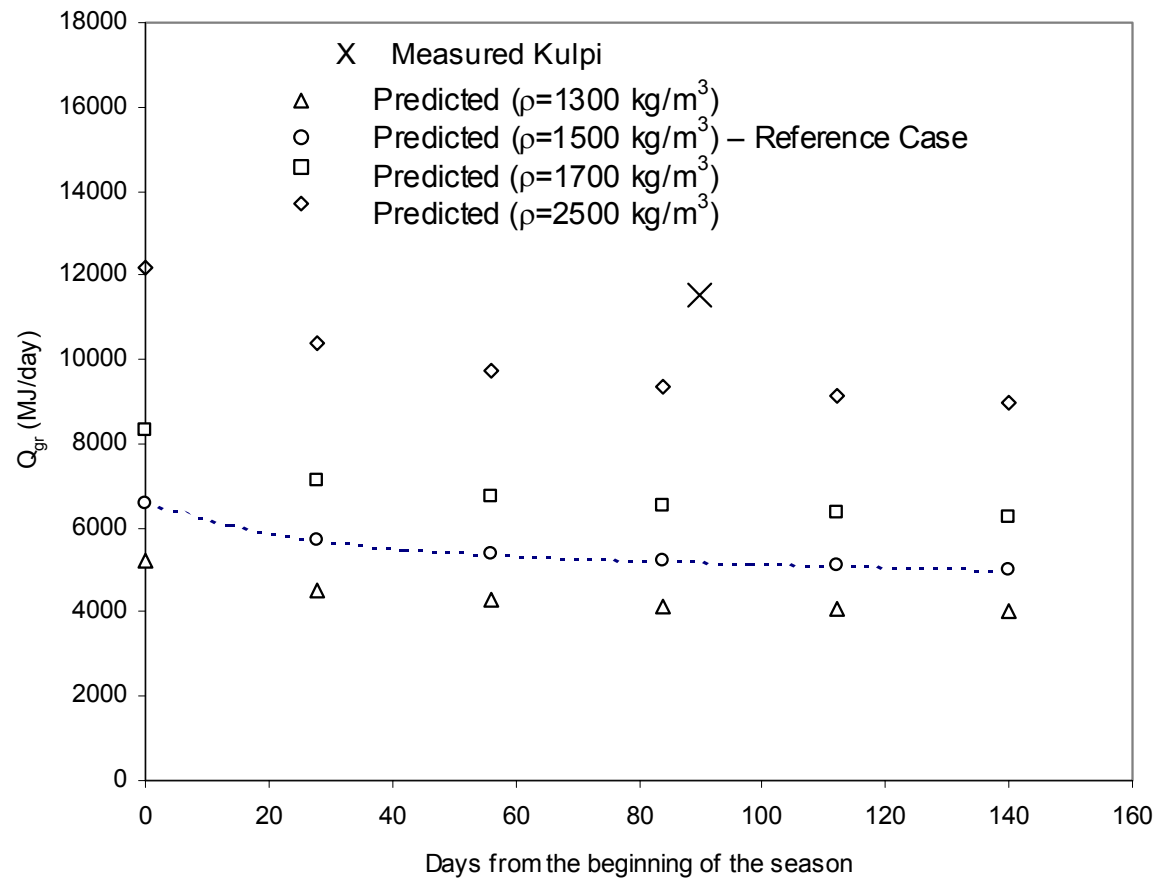

Effect of kiln floor properties on Q_{gr}

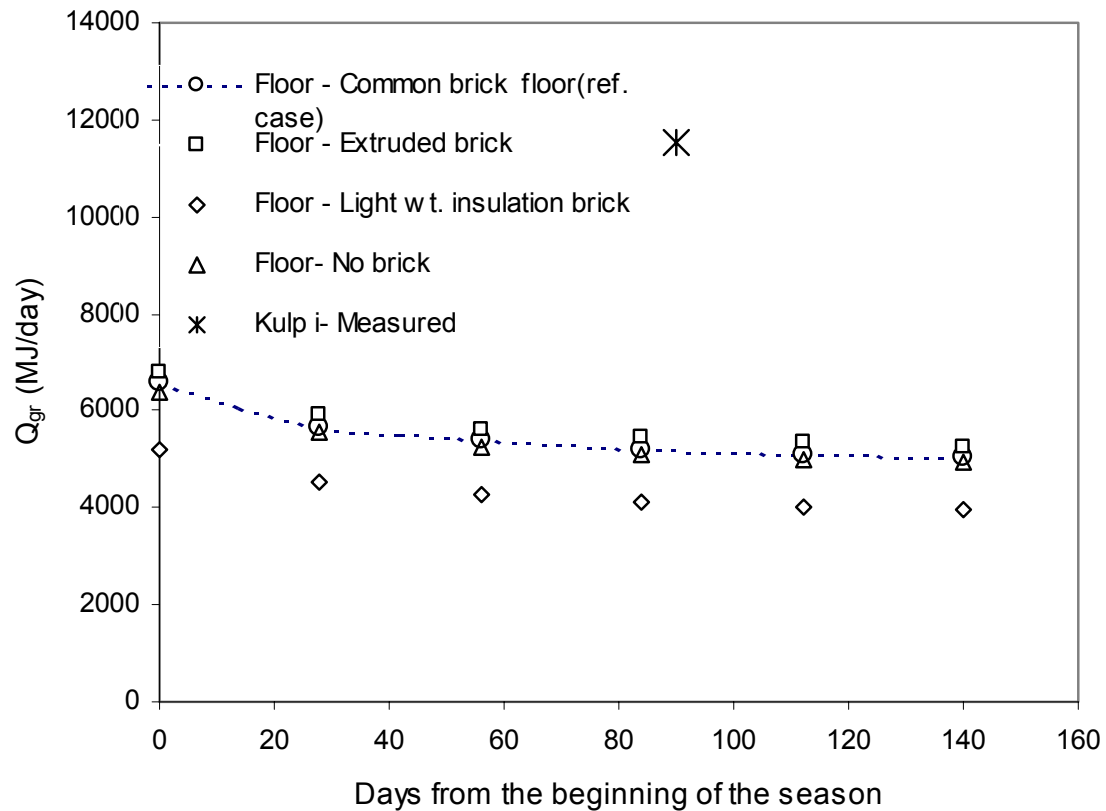

Vertical Shaft Brick Kiln (VSBK)

Rationale for studying VSBK

- New kiln:
 - Chinese origin
 - Introduced in India in 1996
 - Reported to be most energy efficient kiln
 - Suitability for small scale production and for developing countries requirement
- Literature survey:
 - One previous study from China NIFES [1993]. No reported Indian study
- Objectives
 - Energy balance statement
 - Brick temperature distribution.
 - Kiln characteristics

VSBK- Working Principle

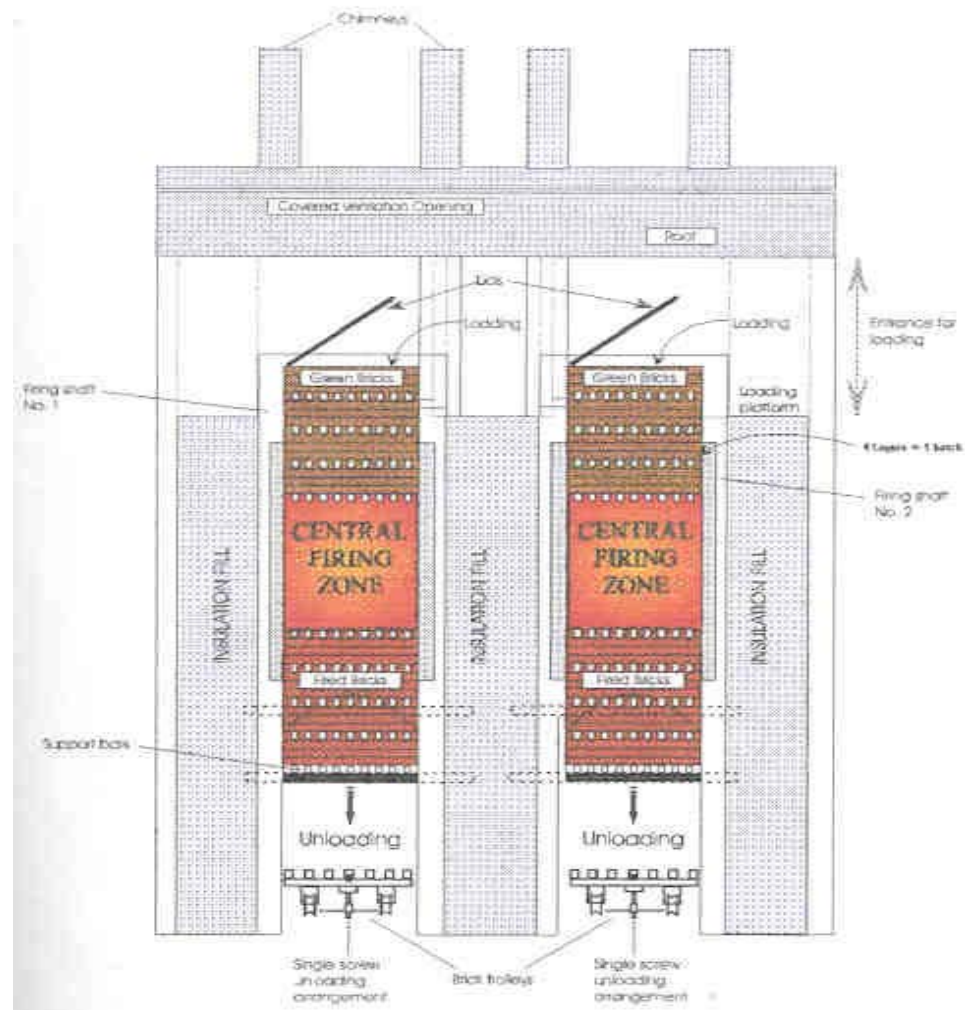

VSBK- Brick Setting

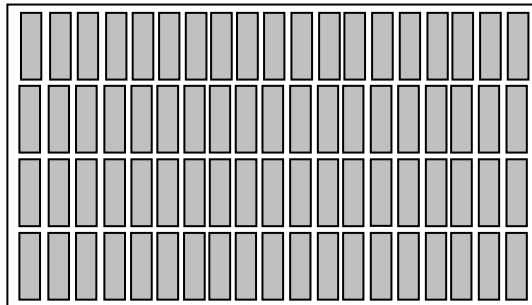
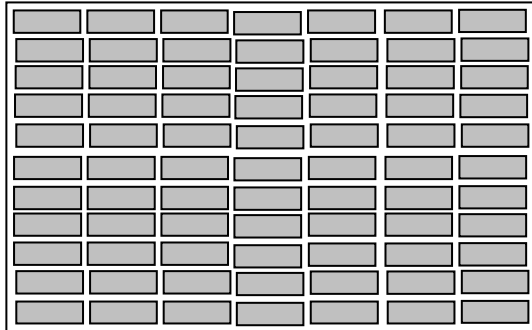

Brick Temperature Measurement

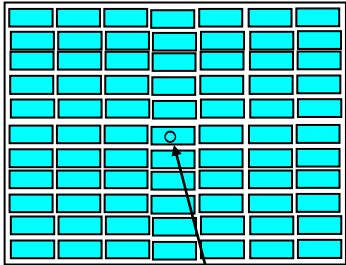
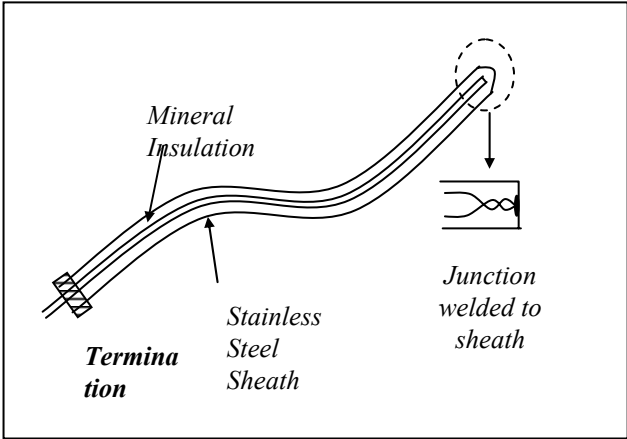
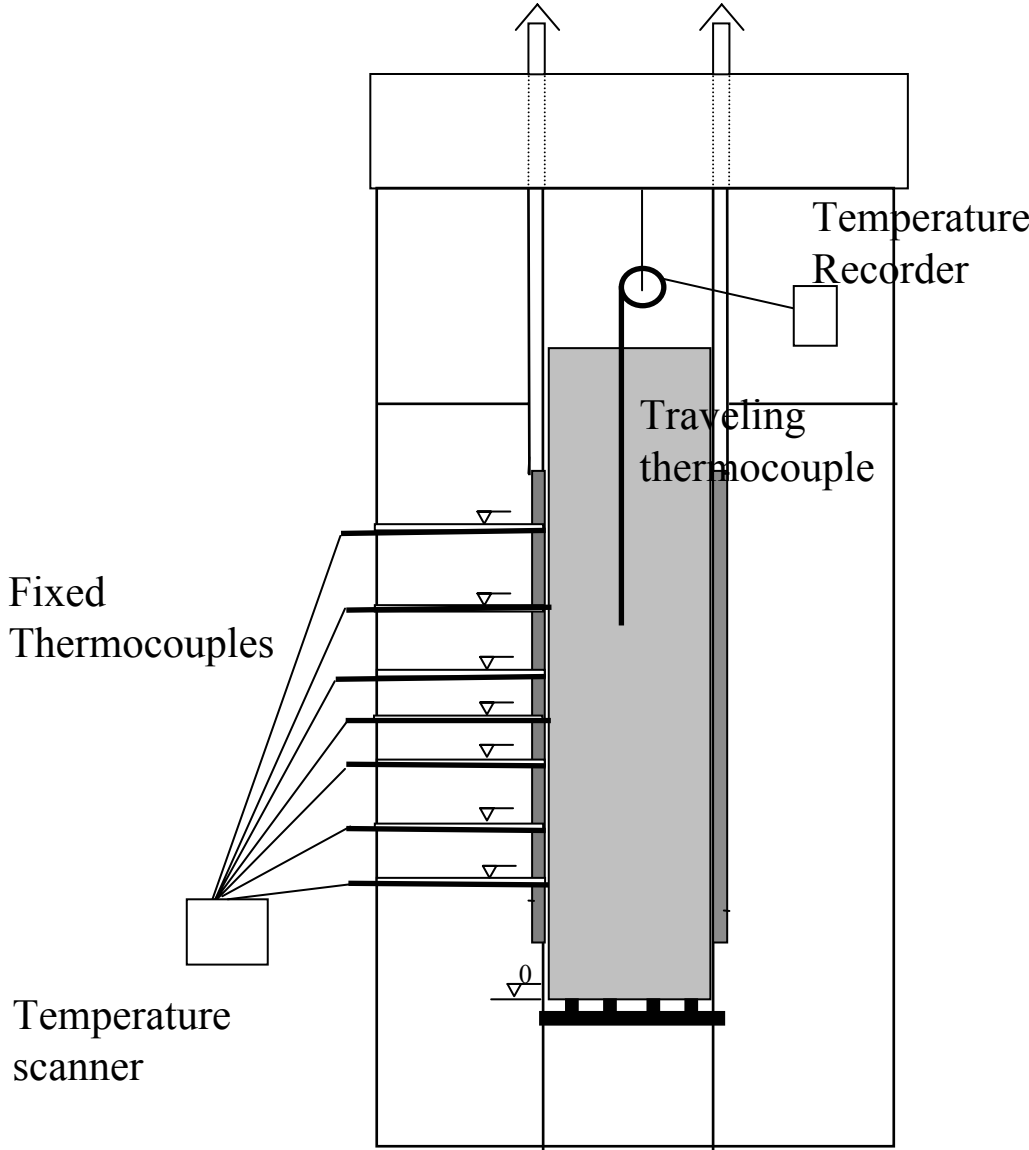

Brick with thermocouple in the center of the setting

VSBK-Brick Temperature

- Short firing cycle
≈ 24 hrs.
- High heating rate
≈ 140°C/h
- Cooling rate
≈ 110°C/h
- High brick unloading temperature
≈ 200 °C

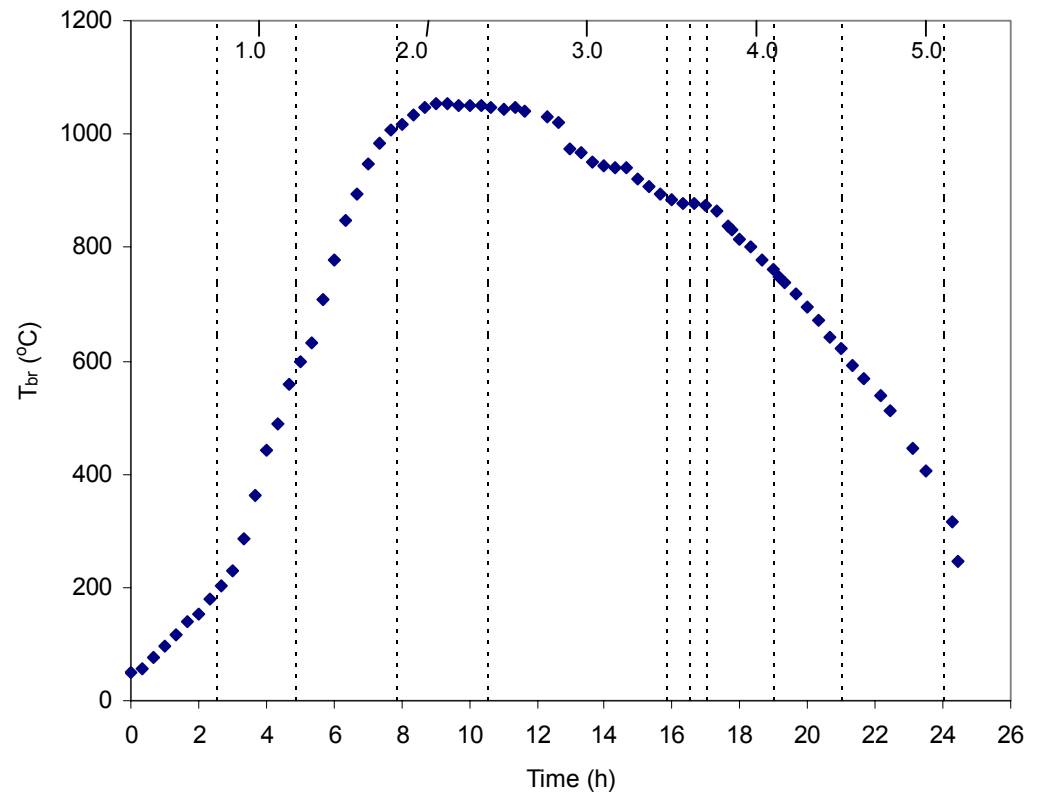

VSBK-Energy Balance

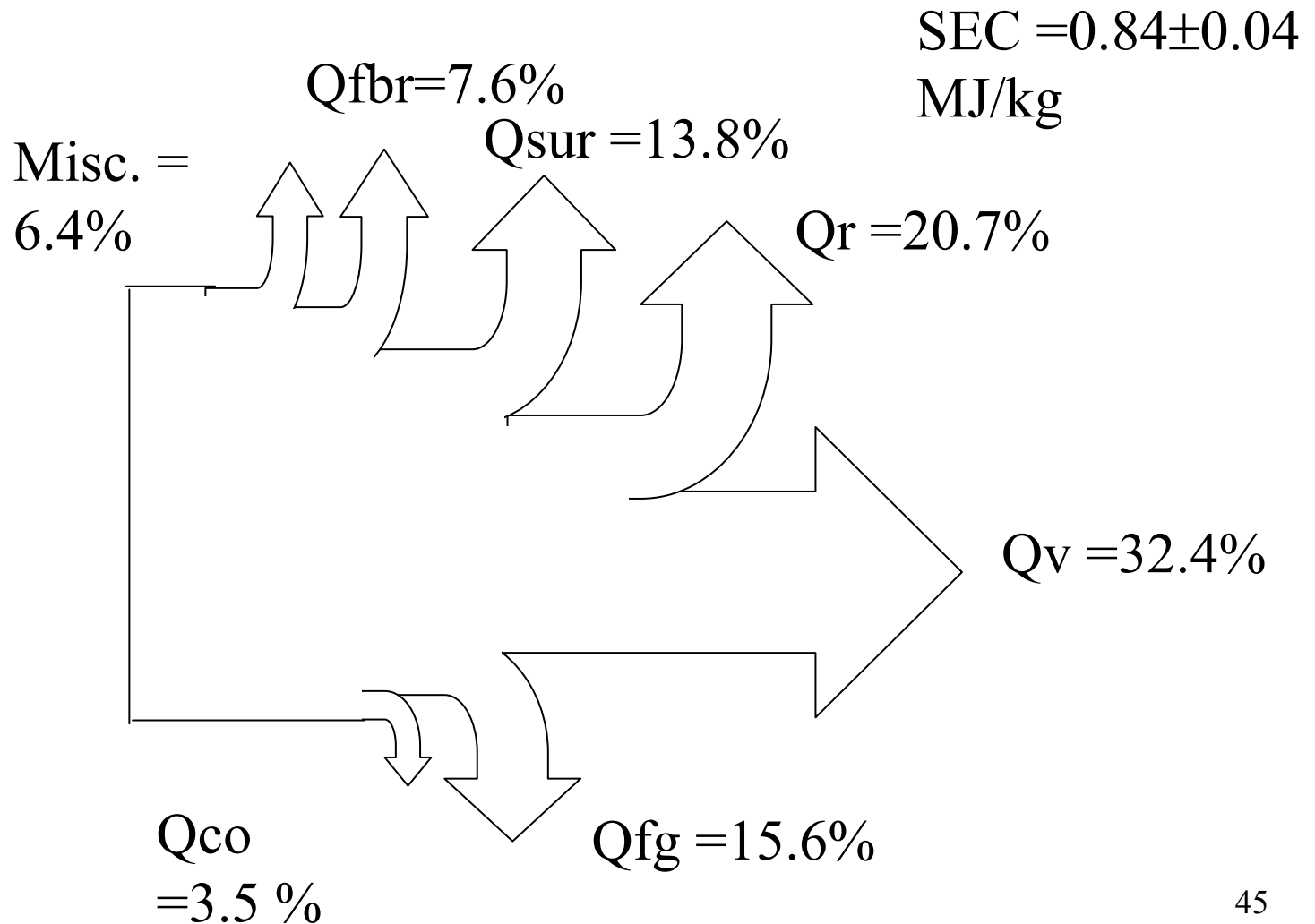

VSBK – Important Characteristics

(Based on data from 16 VSBK studies in India)

- Consistently low SEC (0.76 –1.16 MJ/kg)
 - Seems to be independent of the production rate
- $\lambda (m_{\text{air}}/m_{\text{brick}}) \approx 1$
 - ideal value for λ from energy efficiency considerations
- Relatively high CO emissions
 - 1.16 to 4.38 g/MJ
 - Typical value for hand fired furnaces = 1.5 g/MJ

1-D Heat Transfer and Combustion Model for VSBK: Simplifying Assumptions

- 1- D flow
- Counter current heat exchanger
- Steady state operation
- Coal assumed to move with bricks at same temperature
- Gas is assumed to be non-participating in radiation heat transfer
- Momentum equation not solved
- Split air flow (20% through side gaps, 80% through setting)

Coal Combustion

- Devolatilisation
 - Two step mechanism of Kobayashi et al [1976] used to calculate mass rate of volatile generation.
 - Volatile composition calculated

- Surface Reactions

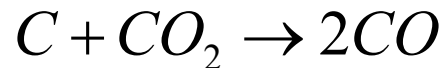
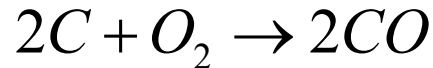

- Gas Phase Reactions:

4-step quasi global mechanism based on oxidation of CO, C₂H₄, H₂, C_nH_{2n+2} used

Energy conservation for air

- Heat from gas phase reactions accounted in air.
- Convective heat exchange between air and inner shaft wall.
- Convective heat exchange between bricks and air

$$St = 0.8432 Re^{-0.2249} \quad 185 < Re < 360(\text{experimental})$$

$$St = 0.04285 Re^{0.3} \quad 5 < Re < 100(\text{packedbeds})$$

– Re calculated based on superficial velocity

Energy conservation for Brick

- Heat from surface reactions accounted in brick.
- Radiation heat exchange between bricks and shaft wall.
- Convective heat exchange between bricks and air

$$St = 0.8432 Re^{-0.2249} \quad 185 < Re < 360(\text{experimental})$$

$$St = 0.04285 Re^{0.3} \quad 5 < Re < 100(\text{packedbeds})$$

- Re calculated based on superficial velocity

Computational Details

- Grid : 1000 grid points
- Gauss-Seidel method
- Convergence criteria: $CC \max < 10^{-4}$

$$CC = \frac{\phi_P^n - \phi_P^{n-1}}{\phi_P^n}$$

Input and Output

- Inputs
 - mass flow rates of bricks, air, coal
 - Kiln geometric parameters
 - Brick setting data
 - Brick physical, thermal properties
 - Coal: ultimate and proximate analysis, particle size distribution.
 - Ambient air properties
- Outputs
 - Brick, air and wall temperatures
 - Species concentration (O_2 , CO_2 , CO ...)
 - Heat loss components

Validation of the Model

- For four VSBKs
- Fairly good match
 - Brick temperatures
 - Location of the temperature maxima and maximum temperature
 - Exit O_2 and CO_2 concentrations

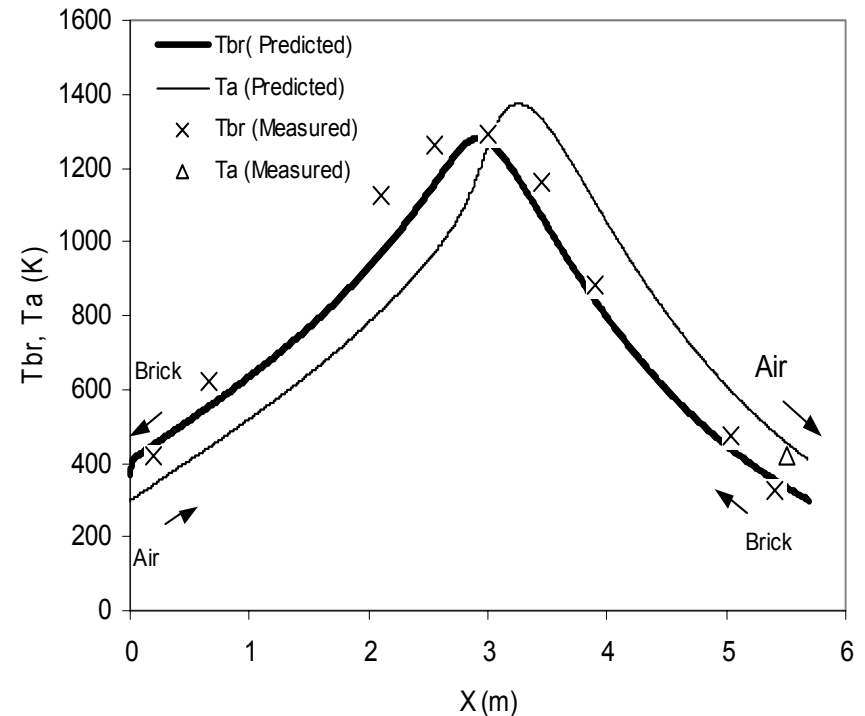
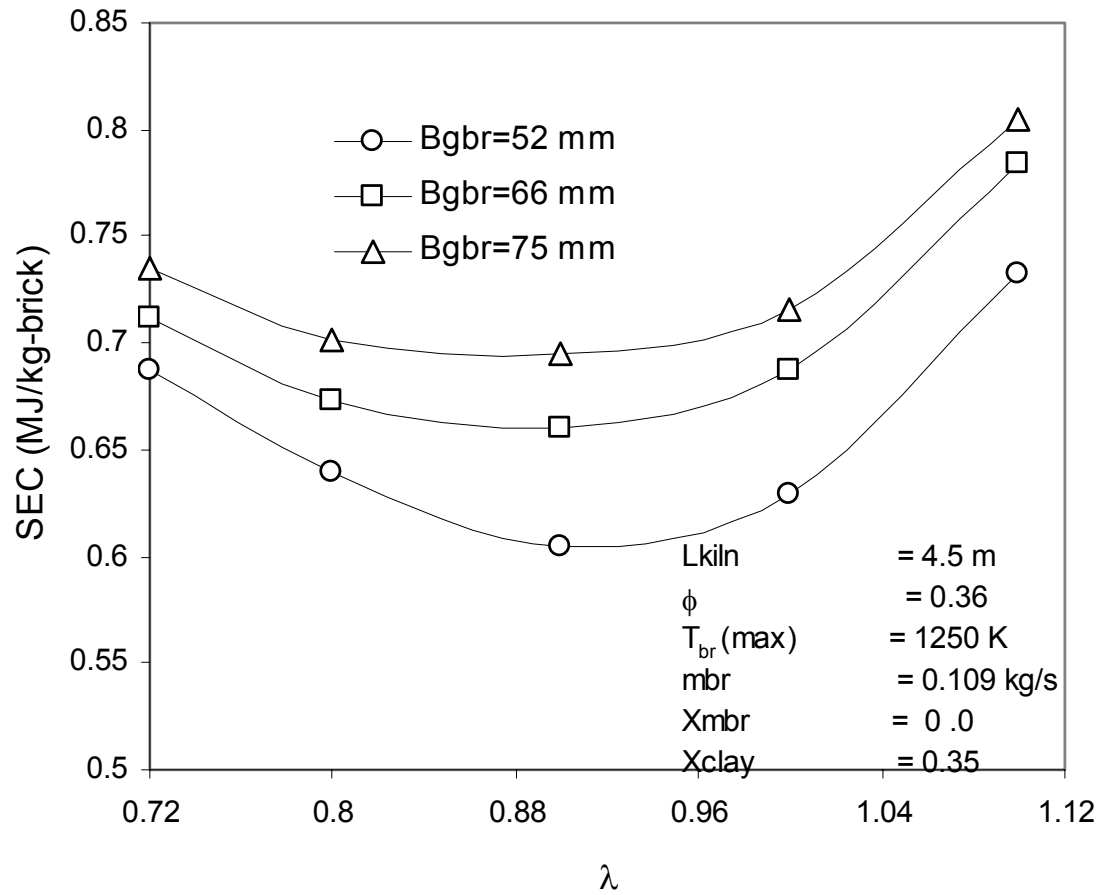

Figure 5.4 Computed and Measured temperatures - VSBK, Varanasi

Parametric Study

- Air to brick ratio (λ)
- Clay fraction (X_{clay})
- Kiln throughput (SPR)
- Void fraction (ϕ)
- Brick thickness (B_{gbr})
- Kiln height (L_{kiln})

Effect of Brick Thickness



Effect of Shaft Height

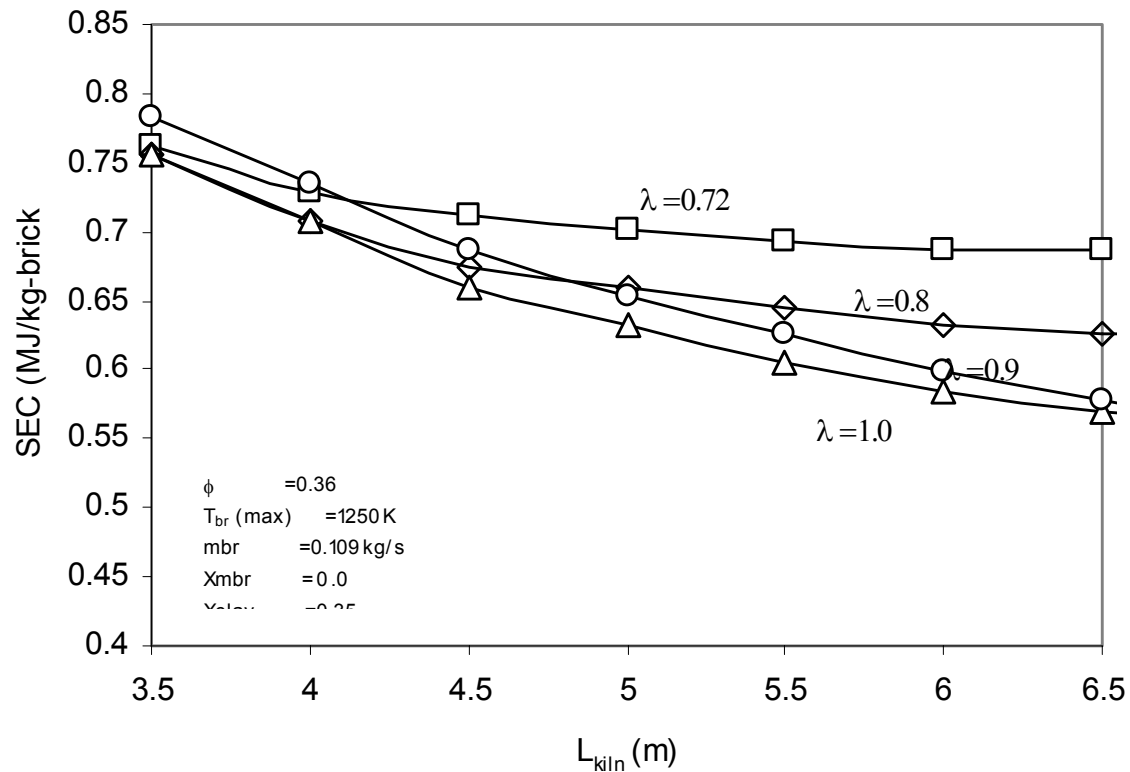

Figure 5.19 Effect of Shaft Height on SEC

Main Contributions

- Development of methodologies and instrumentation for energy /thermal measurements and analysis for BTK and VSBK.
- Novel features of experimentation
 - Measurement of ground temperatures (BTK)
 - Measurement of brick and gas temperatures (BTK)
 - Measurement of brick temperature using traveling thermocouple (VSBK)
 - Measurement of air leakage (BTK)

Main Contributions

- Development of simple mathematical models for studying kiln performance and for developing guidelines for energy conservation
 - 1-D heat transfer model to study ground and roof heat loss in BTK
 - 1-D heat transfer and combustion model for VSBK
- Enhanced understanding of BTK and VSBK systems
 - Mass and energy balance
 - Temperature distribution
 - Gas flow

Suggestions for future work

- Work aimed at development of a new generation annular moving fire kiln to replace BTK:
 - Study the effect of different types of brick setting on heat transfer rates and kiln performance.
 - Use of low cost insulation materials for brick kiln construction.
 - Alternate material for BTK roofing
- Improvements in VSBK
 - Reducing CO emissions
 - Improving the chimney systems to reduce emissions at the top working platform
 - Alternate materials/equipment/ modifications in design to reduce construction and operation cost.
 - Providing better control over firing process